

+
300 series

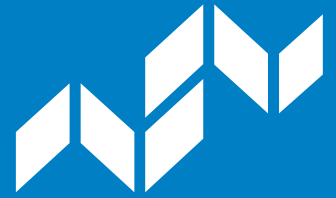

aneeta[®]
A JELD-WEN Company

300⁺ Horizontal
Sashless Slider

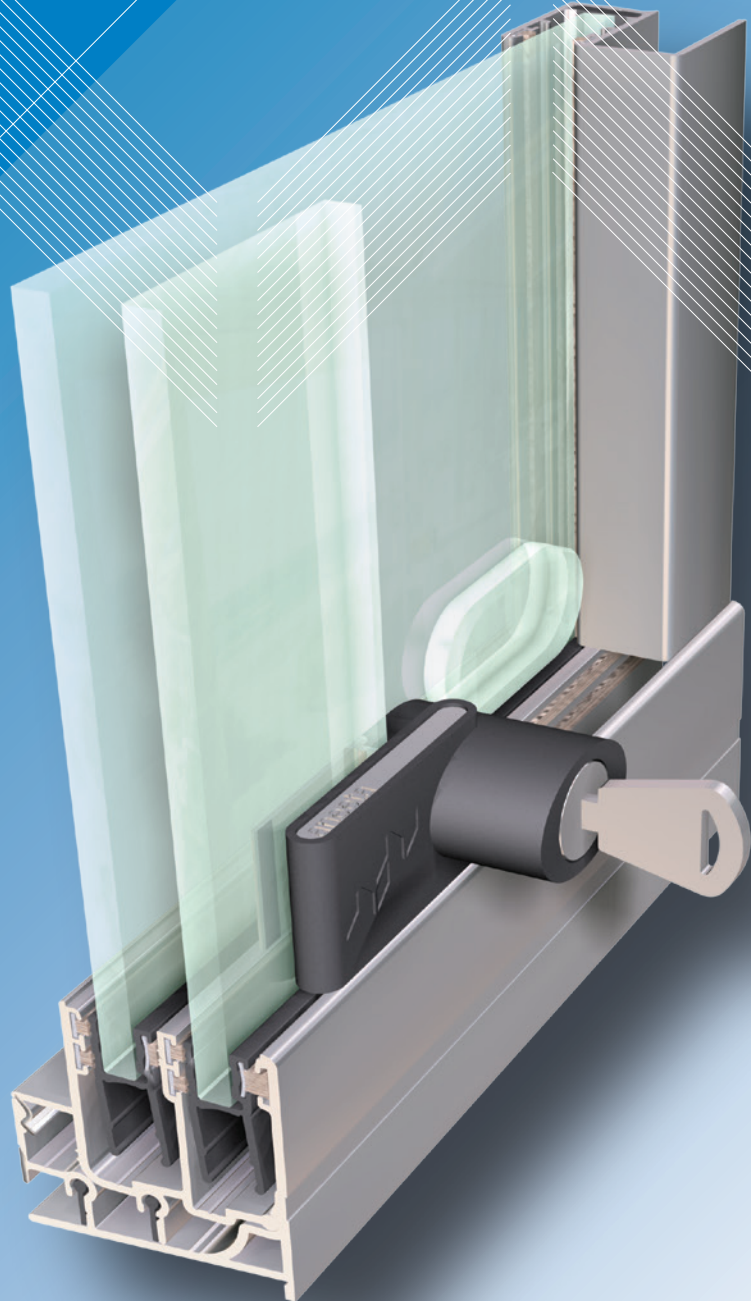

The horizontal sliding window that will meet all your requirements...

Superior weather rating, outstanding flexibility in window sizes and glazing options, clean lines and complete consistency with our highly regarded vertical slider. These are only some of the features of this revolutionary new product. Aneeta, your one stop for sashless window solutions...

300⁺ Horizontal Sashless Slider

We at ANEETA set ourselves the challenge to combine clean slim lines with outstanding performance, security and maximum flexibility for architects and designers.

We are proud to present to you a whole new generation of sliding windows- the 300 series

AUS Patent No. 2008291694
US Patent Pending

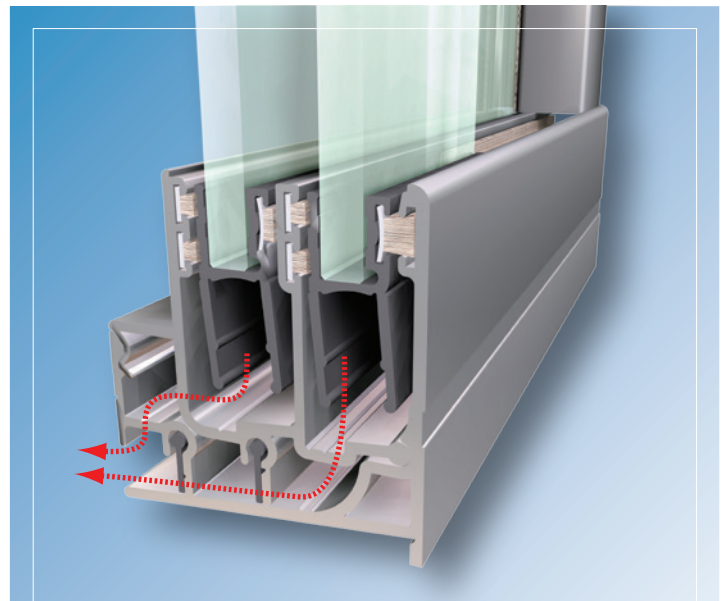

Features

- + tested to N5 rating (300pa water / 2200pa wind load) ideal for exposed areas
- + two separate drainage channels, no visible drainage slots
- + minimal air leakage meets strict requirements for air-conditioned buildings
- + complies with Australian Standard 2047
- + international patents filed
- + increased security once installed the window panes can not be lifted out
- + uses same keyed lock as our vertical double hung systems
- + slimline appearance, visually compatible with our vertical slider
- + both window panes move and can slide past each other for cleaning purposes (most models)
- + available in 6 and 10mm glass,- double glazing is coming soon
minimum height = 250 mm
maximum height = subject to glass type, wind loading, human impact and weight limitations (see general guide below)

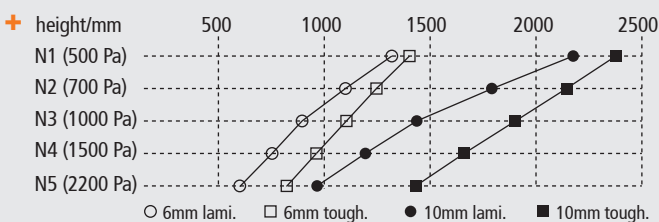

Typical Configurations

